

---

---

---

---

---

---

---

---

---

---

## Check out our other products!

**ComfortHot™**  
Electric Furnace

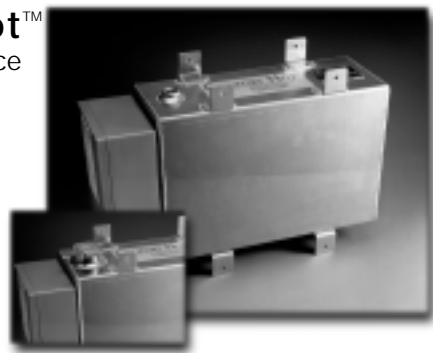

**ConstaHot™**  
Unlimited Hot Water

Contact Information.....	3
Service and Warranty.....	3
Furnace Basics.....	4
System Controls.....	4
Operating Instructions.....	5
Normal Operation.....	5
Main Control Board.....	6
Terms and Definitions.....	6
Fault Codes.....	7
Remote Switch.....	7
Black Exhaust.....	8
No Faults Indicated.....	8
LED Lights (main control board).....	9
Digital (main control board).....	13
Service Procedures.....	17
Hurricane Exploded Diagrams.....	24, 25
Hurricane Furnace Photos.....	26

## CONTACT INFORMATION

Rixen's Enterprises, Inc.  
2700 N Hayden Island Drive • Portland, OR 97217 USA  
1-800-925-6260 • Fax 503-286-5889  
www.rixens.com • E-mail techassist@rixens.com

## SERVICE & WARRANTY INFORMATION

The furnace model and serial # is located on the furnace above the site window and on the back of the cover of the main control board.

Please have the following information available.

- Coach Yr/Model: \_\_\_\_\_
- Furnace Model/Serial # \_\_\_\_\_
- Hour Meter: \_\_\_\_\_
- System Operation: Which part of the system is not working?
  - Furnace start-up
  - Furnace cycle
  - Interior heat
  - Domestic hot water
  - Engine pre-heat
  - Engine waste heat
- What fault codes are displayed? \_\_\_\_\_
- Have you had trouble with the furnace before?  
Date \_\_\_\_\_ Hours \_\_\_\_\_ Problem \_\_\_\_\_  
Date \_\_\_\_\_ Hours \_\_\_\_\_ Problem \_\_\_\_\_  
Date \_\_\_\_\_ Hours \_\_\_\_\_ Problem \_\_\_\_\_
- Do you have? Tools \_\_\_\_\_ Test meter \_\_\_\_\_

## FURNACE BASICS

The furnace performs the tasks listed below.

**NOTE:** *It must be turned on to perform one or all of the tasks.*

- **Interior heating** - Supplies hot water to your fan units.
- **Domestic water** – Heats the domestic water.
- **Engine pre-heat** (optional) – Pre-heats the engine coolant.

### Additional system function

- **Engine waste heat** – When traveling the engine coolant is circulated through an exchanger to heat the coolant in the furnace.

## SYSTEM CONTROLS

- **Remote switch** – This switch is located inside the coach. This switch will turn the furnace on and off.
- **Fan switch** – There may be several of these located throughout the coach. They turn the fan units on and off and control the fan speed.
- **Thermostats** – There is a thermostat for each heating zone in your coach. You set these to the desired temperature in each heating zone.
- **Engine waste heat switch** – This activates the system pump to circulate the coolant in the furnace. It is normally located near the dashboard.
- **Engine pre-heat switch** (optional) – This switch would be located inside the coach. It activates a circulation pump to pre-heat the engine coolant.
- **Service switch** – This switch is located on the side of the main control board near the furnace. It must be “on” for the furnace to operate. It is used to troubleshoot the furnace.

## OPERATING INSTRUCTIONS

### Interior Heating

1. Turn on the remote switch.
2. Set the thermostats to your desired temperatures.
3. Turn on the fan units and select the fan speed in each zone.

**NOTE:** *The heater coolant has to come to temperature before the fan units will blow warm air.*

### Domestic Water

1. Turn on the remote switch.

### Engine waste heat

1. Turn on the engine waste heat (system circulation pump)

### Engine Pre-heat (optional)

1. Turn on the remote switch.
2. Turn on the engine pre-heat switch.

## NORMAL FURNACE OPERATION

1. The service switch is "on".
2. The remote switch is turned "on".
3. There is a "call" for heat (interior, domestic water, engine coolant).
4. The igniter is glowing.
5. The combustion air intake fan in the furnace is running.
6. The system circulation pump is running.
7. The fuel pump delivers fuel.
8. The compressor turns on.
9. The fuel valve opens and fuel is drawn into the air-aspirating nozzle.
10. The fuel is atomized and sprayed into the combustion chamber.
11. Combustion is started.

## MAIN CONTROL BOARD

- The main control board is located in the same bay area near the Hurricane furnace.
- There is a 9-pin connector and cord between the Hurricane furnace and the main control board.
- There is a service switch located on the side of the main control board.
- There are two styles of the main control board. The early versions have "LED" light indicators on the face of the main control board and words corresponding to them. Later versions have a digital read out.
- The version of the main control board is indicated on a white sticker inside the cover of the main control board.
- If the cover of the main control board is removed you will see two (2) circuit board sections. The upper section on the circuit board controls the operation of the furnace. The lower section on the circuit board controls the heating zones inside your coach.

■ LED lights main control board has two (2) separate circuit boards inside.

■ Digital main control board has one circuit board inside.

## TERMS & DEFINITIONS

- **Bridge** - Troubleshooting procedures may require you to bridge or connect two terminals or wires together. This can be done with a paper clip or a wire with alligator clips.
- **Bypass** – Troubleshooting procedures may require you to bypass a component to determine if a part is causing a fault.
- **Open circuit** – There is no power flowing.
- **Closed circuit** – The power is flowing.
- **Circuit** – the complete path of an electric current.
- **Short circuit** – a connection where current is not intended to flow.

## FAULT CODES

- To determine the fault code the remote switch (inside the coach) must be in the "on" position.
- If it is in the "off" position, it will be indicated on the main control board.
  - Digital -  is displayed and the small red Led near the lower corner of the display will not be lit.
  - Led lights - "remote open" is lit.
- If the remote switch was off, you need to turn it "on" and restart the furnace to check for fault codes.
- Proceed to the fault listed.

**NOTE:** *Faults are cleared by cycling the furnace on and off with the remote or service switch.*

## REMOTE SWITCH

The board indicates "remote open" (off) and the remote switch is in the "on" position.

1. Check to make sure the cord is properly plugged into the main control board and into the remote switch.
2. If it is properly plugged in and the light does not go off when the remote switch is in the "on" position then you will need to try another 6-pin phone cord. Another cord can be connected by unplugging the existing cord and plugging in the new cord. Route the cord between the main control board and the remote switch. If the "remote open" indicator goes off when the remote switch is "on", then replace the cord.

**NOTE:** *You can secure the cord temporarily in place until it can be properly routed at a factory service center.*

3. If the new cord does not make a difference, then you need to check or replace the remote switch.
4. If the remote switch has been replaced and the problem still occurs then you need to replace the main control board.

## BLACK EXHAUST (sulfur smell) or orange flame

1. Check the combustion air fan.
2. Check the fuel nozzle.
3. Check the air filters.
4. Remove the exhaust and run the furnace.
  - If the condition goes away, then the exhaust is plugged.
5. Remove the counter flow tube and check for damage.

## NO FAULTS INDICATED furnace will not run

The remote and service switches are in the "on" position, there are no faults indicated and the furnace will not run.

**NOTE:** *A furnace that stops and starts often without indicated faults has a problem with the cycling aqua stat or the thermostats.*

1. Check the system lights on the main control board.
  - Digital** – Two green LED lights are lit.
    - Power On - above digital display.
    - Circulation Pump On - below digital display.
  - LED lights** – Three green LED lights are lit.
    - Power On - top light.
    - Burner On – 2<sup>nd</sup> light from top.
    - Water Pump On - very bottom light.
  - LED main control board** – Power On light lit, Burner On light is not.
    - Check "Fan" fuse.
    - Bridge (connect) terminals TC and T1.
      1. If the furnace fires – then there is a thermostat problem.
      2. If the furnace does not fire – then check the cycling aqua stat.
2. Check system fuses on the main control board (upper circuit board).
  - Digital main control board** – There are four system fuses.
  - LED lights main control board** – There are three system fuses. Version V12 and newer have four fuses.
3. Check for power to the main control board.

The power and ground terminals are located on the left hand side of the top circuit board below the fuses.

## LED LIGHTS MAIN CONTROL BOARD

Version V12 pictured below.

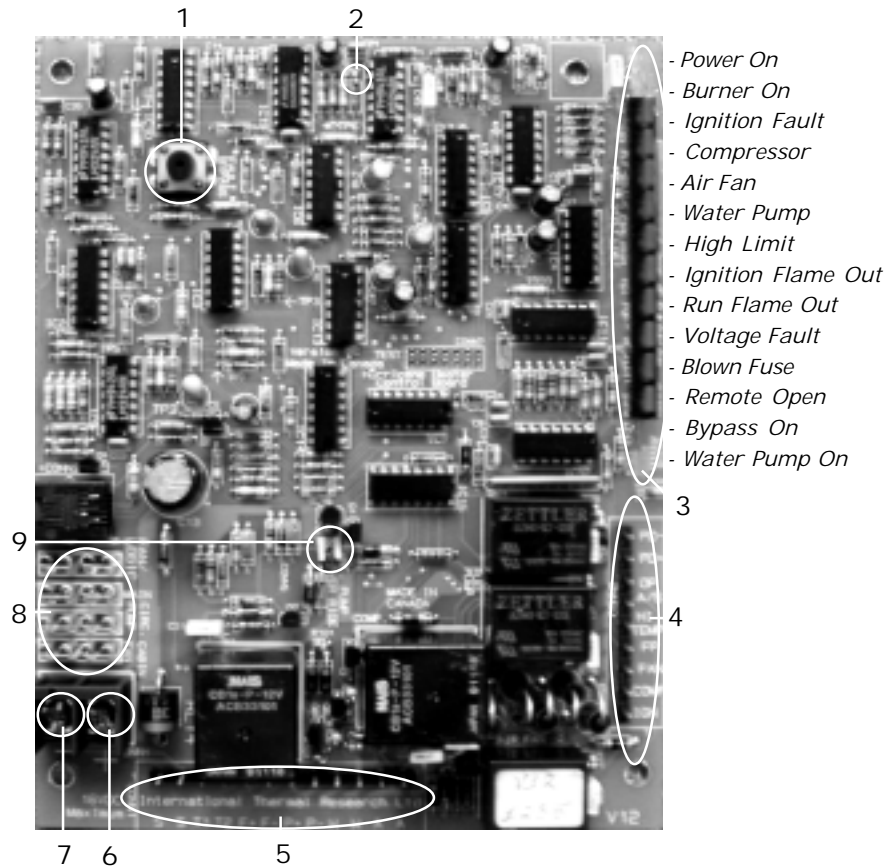

1. By-Pass Bridge Clip/Button
2. Test Points
3. LED Lights
4. 9-Pin Connector
5. Zone Connections
6. Power Terminal
7. Ground Terminal
8. System Fuses
9. Pump Bridge Clip

## LED LIGHTS

main control board

### Ignition Fault

The igniter is open (no current) or shorted.

1. Check the igniter and connections.
2. Reset the furnace by switching the remote or service switch off and on.

### Compressor

The air compressor has shorted.

1. Check the air compressor.
2. Reset the furnace by switching the remote or service switch off and on.

### Air fan

The combustion fan is open (no current) or shorted.

1. Check the combustion fan.
2. Reset the furnace by switching the remote or service switch off and on.

### Water pump

The water pump has shorted.

1. Check the water pump.
2. Reset the furnace by switching the remote or service switch off and on.

### High Limit

The furnace has reached the high temperature limit.

1. Check the coolant level in the expansion tank located in the furnace compartment and fill as needed. (50/50 water/ethylene glycol)

### WARNING:

*Hot coolant can cause severe burns! Never open the cap when the system is hot.*

2. Check the system pump fuse and confirm that the pump is working.

3. Activate the system pump and look inside expansion tank to see if the coolant is moving.

-Coolant IS moving.

1. Check the high-limit aqua stat for a manual reset button (new versions are self-resetting).
2. Bypass the high limit aqua stat by grounding the orange-black wire on the main control board to the main control board base. This is located on the vertical wire strip terminals on the upper circuit board.

3. Restart the furnace.

- If it does not fault again, then check the wiring before replacing the high-limit aqua stat.
- If the high-limit fault code is still displayed after bypassing the high limit aqua stat (step 2), then you need to replace the main control board.

-Coolant IS NOT moving.

1. Check the summer loop ball valves and make sure that at least one is open.
2. Bleed the air from the pump by loosening the output hose. This may need to be done more than once.

**CAUTION:** *Do not remove the hose or you will lose coolant.*

*The pump is rated at six gpm.*

3. Check for plugged or pinched lines.

**Ignition Flame Out** The flame did not ignite.

1. Check the fuel supply.
2. Check for white smoke out the exhaust.

-White smoke

1. Check the fuel supply.
2. Bleed air from the fuel.
3. Check fuel pump for pulsing.
4. Check the fuel solenoid.
5. Check fuel regulator.

The fuel pickup for the furnace is normally located at or above the 1/4 tank level on the fuel tank. When checking for fuel supply make sure that there is fuel above this level.

6. Check compressor.
7. Check the combustion air fan.

-No smoke

1. Check photo diode (photo eye or flame sensor)
3. Reset the furnace by switching the remote or service switch off and on.

**Run Flame Out** The flame went out.

1. Check the fuel supply.
2. Check for white smoke out the exhaust.

-White smoke

1. Check the fuel supply.
2. Bleed air from the fuel.
3. Check fuel pump for pulsing.
4. Check the fuel solenoid.
5. Check fuel regulator.
6. Check compressor.
7. Check the combustion air fan.

-No smoke

1. Check photo diode (photo eye or flame sensor)
3. Reset the furnace by switching the remote or service switch off and on.

The fuel pickup for the furnace is normally located at or above the 1/4 tank level on the fuel tank. When checking for fuel supply make sure that there is fuel above this level.

**Voltage Fault**

The supply voltage to the furnace is below 10.5 VDC or above 15.5 VDC.

1. If the furnace shuts down, then reset the furnace by switching the remote or service switch off and on.
2. If the problem continues, then check the supply voltage.

**Blown fuse**

One of the fuses on the main control board has blown.

1. Check system fuses on the main control board (upper circuit board) and replace as needed.
2. Reset the furnace by switching the remote or service switch off and on.

## DIGITAL MAIN CONTROL BOARD

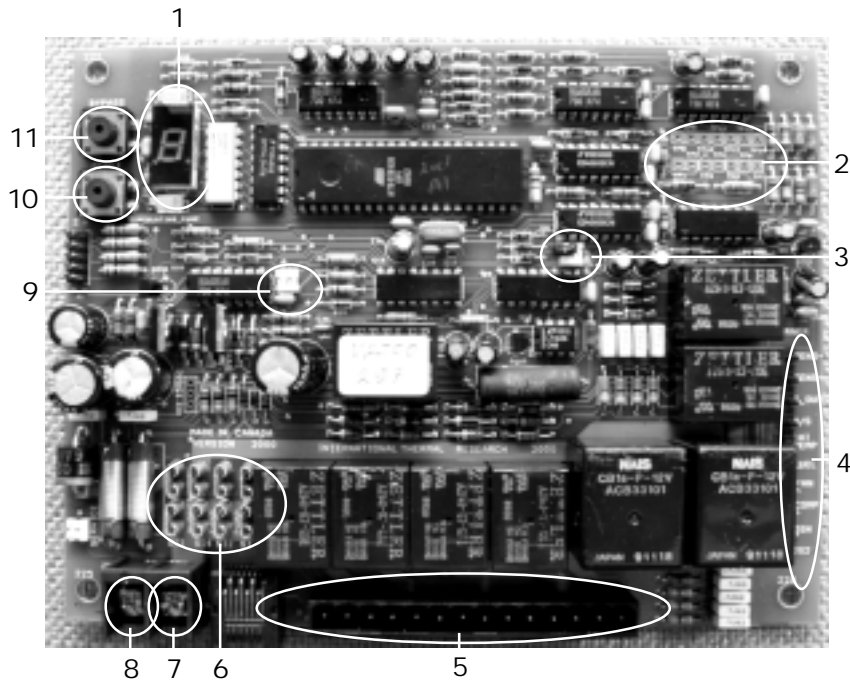

1. Digital Read Out
2. Test Points
3. Pump Bridge Clip
4. 9-Pin Connector
5. Zone Connections
6. System Fuses
7. Power Terminal
8. Ground Terminal
9. Fan Bridge Clip
10. Reset Button
11. Bypass Button

## DIGITAL

main control board

A short-circuit fault must be reset using the "service" switch.

### 0 - Voltage high or low

The supply voltage to the furnace is below 10.5 VDC or above 15.5 VDC.

1. If the furnace shuts down, then reset the furnace by switching the remote or service switch off and on.
2. If the problem continues, then check the supply voltage.

### 1 - Overheat

The furnace has reached the high temperature limit.

1. Check the coolant level in the expansion tank located in the furnace compartment and fill as needed. (50/50 water ethylene glycol)

**WARNING: Hot coolant can cause severe burns!**

*Never open the cap when the system is hot.*

2. Check the system pump fuse and confirm that the pump is working.
3. Activate the system pump and look inside expansion tank to see if the coolant is moving.

#### -Coolant IS moving.

1. Check the high-limit aqua stat for a manual reset button (new versions are self-resetting).
2. Bypass the high limit aqua stat by grounding the orange-black wire on the main control board to the main control board base. This is located on the vertical wire strip terminals on the upper circuit board.
3. Restart the furnace.

-If it does not fault again, then check the wiring before replacing the high-limit aqua stat.

-If the high-limit fault code is still displayed after bypassing the high limit aqua stat (step 2), then you need to replace the main control board.

-Coolant IS **NOT** moving.

1. Check the summer loop ball valves and make sure that at least one is open.
2. Bleed the air from the pump by loosening the output hose. This may need to be done more than once.

**CAUTION:** *Do not remove the hose or you will lose coolant.*

*The pump is rated at six gpm.*

3. Check for plugged or pinched lines.

## 2 – Fuse blown

One of the fuses on the main control board has blown.

1. Check system fuses on the main control board and replace as needed.
2. Reset the furnace by switching the remote or service switch off and on.

## 3 – Fuel pump/solenoid

The fuel pump or solenoid has shorted.

1. Check the fuel pump and solenoid.
2. Reset the furnace by switching the **service** switch off and on.

## 4 – Igniter

The igniter is open (no current) or shorted.

1. Check the igniter and connections.
2. Reset the furnace.
  - Open – Reset the furnace by switching the remote or service switch off and on.
  - Shorted - Reset the furnace by switching the **service** switch off and on.

## 5 – Combustion fan

The combustion fan is open (no current) or shorted.

1. Check the combustion fan.
2. Reset the furnace.
  - Open – Reset the furnace by switching the remote or service switch off and on.
  - Shorted - Reset the furnace by switching the **service** switch off and on.

## 6 – Water pump

The water pump has shorted.

1. Check the water pump.
2. Reset the furnace by switching the **service** switch off and on.

## 7 – Flame out

The flame went out or did not ignite.

1. Check the fuel supply.
2. Check for white smoke out the exhaust.

### -White smoke

1. Check the fuel supply.
2. Bleed air from the fuel.
3. Check fuel pump for pulsing.
4. Check the fuel solenoid.
5. Check fuel regulator.
6. Check compressor.
7. Check the combustion air fan.

### -No smoke

1. Check photo diode (photo eye or flame sensor)
3. Reset the furnace by switching the remote or service switch off and on.

## 8 – Compressor

The air compressor has shorted.

1. Check the air compressor.
2. Reset the furnace by switching the **service** switch off and on.

The fuel pickup for the furnace is normally located at or above the 1/4 tank level on the fuel tank. When checking for fuel supply make sure that there is fuel above this level.

## SERVICE PROCEDURES

### Air Accumulator

*Listed in Alphabetical Order*

The air accumulator is installed inline to prevent air from reaching the burner and shutting it down.

#### 1. Bleeding

- Locate the bleeder valve on the top of the furnace case.
- Start furnace.
- Open the bleeder valve one turn while checking for fuel flowing out

**NOTE:** *If the air accumulator has to be bleed often, then the fuel lines or fittings may have an air leak.*

### Air filter

There is an air filter on the intake line of the compressor pump.

1. Check the filter inlet for debris.
2. Check the condition of the filter.
  - If it is dirty, then replace it.

### Bleeding air/fuel

1. Check fuel supply.
2. Check fuel line and fittings.
3. Check fuel pump operation.
4. Bleed the air accumulator.
  - Locate the bleeder valve on the top of the furnace case.
  - Start furnace.
  - Open the bleeder valve one turn while checking for fuel flowing out

### Bypass mode

This is a service feature that allows you to bypass the safety devices for five minutes.

- LED lights main control board – These boards use a bridge clip or button for bypass mode.
- Digital main control board – These boards have a bypass button.

## SERVICE PROCEDURES

(cont.)

### Combustion air fan

The combustion air fan supplies the air for combustion and clears the exhaust during furnace shutdown.

#### Testing

1. Remove the cover from the end of the furnace accessing the burn chamber.
2. Locate the opening in the upper left corner of the burn chamber.
3. Start furnace.
4. Place your hand over the opening and check for air.
  - Before furnace fires.
  - During furnace operation.
  - After furnace burn cycle.
5. Check the amperage draw – 2-amp maximum.

### Compressor

The compressor pumps air across the nozzle and draws the fuel into the burner.

#### Testing

1. Remove the panel w/site glass from the end of the furnace.
2. Remove the nozzle assembly from the counter flow tube.
3. Start furnace (it will try to start twice and then it will fault).
4. Check for air out the end of the nozzle.
  - Place your finger over the end of the opening.
  - Plumb a gauge between airline and nozzle – 9 to 11 lbs. of pressure.
5. If there is no air, then replace the compressor.

### Counter flow tube

This holds the nozzle assembly.

**Cycling Aqua stat**

1. You must have power at T1, T2, T3, or T4. These terminals are located at the bottom of the lower circuit board.
2. Bridge or eliminate the cycling aqua stat from the system.
  - At the furnace:
    1. Locate the cycling aqua stat on the furnace. It is at the top center of the furnace under a 2" x 3" plate.
    2. Locate the two green wires attached to the aqua stat and bridge (connect) them.
  - At the main control board:
    1. Locate the 9-pin cord connection underneath the fault lights.
    2. Locate the third and fourth wires (green) from the top of the terminal and bridge (connect) them.
3. If the furnace does not start then the main control board needs to be replaced.

**Fuel Pump**

1. Pulse rate
  - Testing.
    1. Open bleeder valve one turn and activate pump.
    2. Touch pump for pulse – 4 to 5 pulses per second.
    3. Close bleeder valve.
    4. Touch pump for pulse – 1 pulse per second.
  - No pulse.
    1. Check pump fuse.
    2. Check pump ground wire for proper ground.
    3. Connect 12V DC power directly to pump leads.
    4. If the pump does not operate, then replace the pump.
    5. If the fuse and pump are good, then replace the main control board.

**Fuel Regulator**

The fuel regulator controls the flow of fuel to the nozzle.

Testing

1. Remove the panel from the side of the furnace.
2. Remove the fuel regulator.
  - Diaphragm
    1. The diaphragm should hold vacuum on the output side when the input side is plugged.
    2. If the diaphragm does not hold vacuum, then replace it.
  - Needle seat
    1. Apply pressure to the input side and depress the diaphragm. This can be done with a paperclip.
    2. Air should flow through the fuel regulator.
    3. If air does not flow through, then remove the needle seat and check for a plugged opening.

**Fuel Solenoid**

The fuel solenoid stops the flow of fuel when the furnace is shut-down.

Testing

1. Remove the cover from the end of the furnace accessing the burn chamber.
2. Locate the fuel solenoid.
3. Unplug the wire at the base.
4. Turn the base counter clockwise and remove.
5. Allow the plunger and spring to drop out.
6. Reinstall the base.
7. Remove the nozzle assembly from the counter flow tube and point it downward.
8. Start the furnace and check for a fuel mist from the nozzle.
9. If there is no fuel, then check the fuel regulator or fuel pump.

**Fuses**

If the main fuse continues to blow, then you need to check the amp draw of each component. The main fuse should not exceed 10 amps (LED) or 15 amps (digital).

-Checking component amperage draw.

1. Locate the 9 pin connector that plugs into the lower right corner of the main control board.
2. Set test meter to amperage.
3. Connect one lead to 12V DC power and connect the other lead to the component that you are testing..
4. Test amperage starting at the bottom of the 9 pin connector terminal strip.

- Igniter – red wire w/black stripe – 2 amps
- Compressor – red or red wire w/white stripe – 4.5 amps
- Combustion air fan – white or green/yellow wire – 2 amps
- Fuel pump – blue wire – 1 amp

-Digital main control board:

- Main - 10 amp
- Burner – 15 amp
- Pump – 10 amp (max)
- Fan – 15 amp (max)

-LED lights main control board:

- Main – 10 amp
- Pump – 10 amp
- Fan – 10 amp (max)

Version V12:

- Fan Logic - 5 amp
- Main - 10 amp
- Pump - 10 amp (max)
- Fan - 10 amp (max)

**Igniter**

The igniter fires the air/fuel mixture.

Testing

1. Remove the panel w/site glass from the end of the furnace accessing the burn chamber.
2. Remove the igniter from the furnace by removing the clip and thumbscrew.
3. Connect the wire leads to a 12V DC source and ground the housing.
  - The pin should glow.
  - The igniter tip should draw less than two amps.
4. Reinstall the igniter and test the cycle time.
  - Seven seconds before the furnace starts.
  - Seven seconds after the furnace fires.
  - If the igniter stays on longer, then replace the main control board.

**Photo Diode (photo eye or flame sensor)**

The photo diode monitors the operation of the flame.

Testing

1. Remove the cover on the main control board and engage the bypass.
2. Locate the voltage test point on the main control board.
3. Start the furnace.
4. Measure the voltage.
5. If the voltage is below 2 volts, then check the flame color in the burner chamber.

6. Blue flame – indicates a lean fuel mixture.
  - Check and clean the nozzle in the burn chamber.
  - Check the fuel solenoid or bypass it.
  - Check the fuel regulator for a plugged needle seat.
  - Check the fuel pump for flow.
7. If there is no voltage, check the wire connections, and then replace the photo diode.

**Water Pump**

The water pump circulates the coolant through the furnace, hot water tank, and the fan units.

1. Fault
  - Check pump fuse.
  - Check pump ground wire for proper ground.
  - Connect 12V DC power directly to pump leads.
  - If the pump does not operate, then replace the pump.
  - Check amperage draw – 3.5 amp maximum.
  - If the fuse and pump are good, then replace the main control board.
2. Brushes
  - Remove the two caps on the back of the pump.

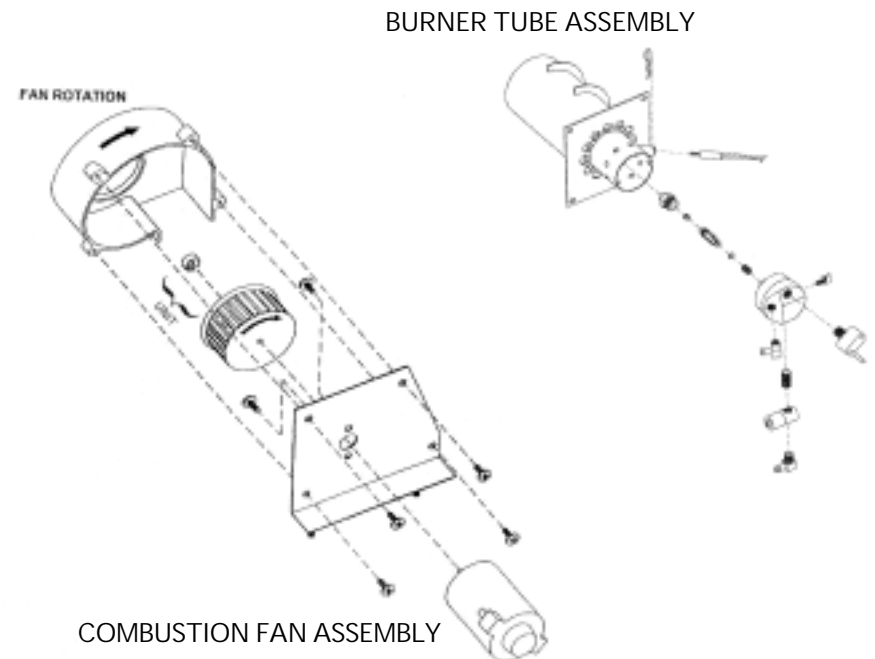
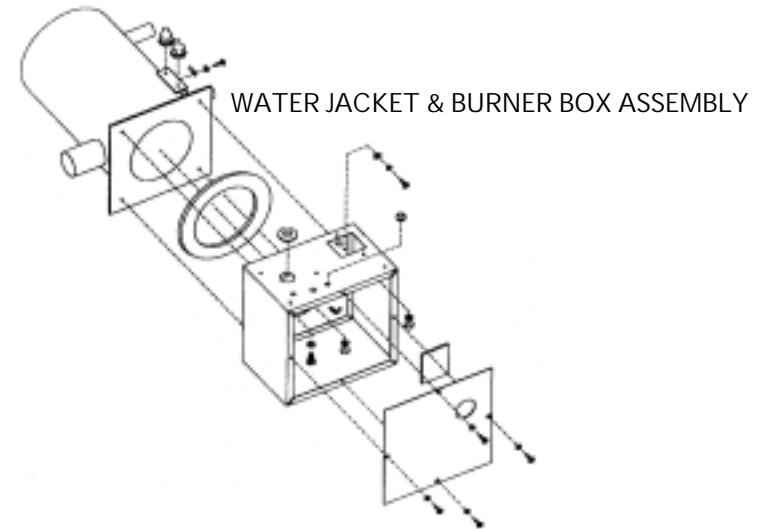

# HURRICANE HEATER EXPLODED VIEWS

COMPONENT BOX ASSEMBLY

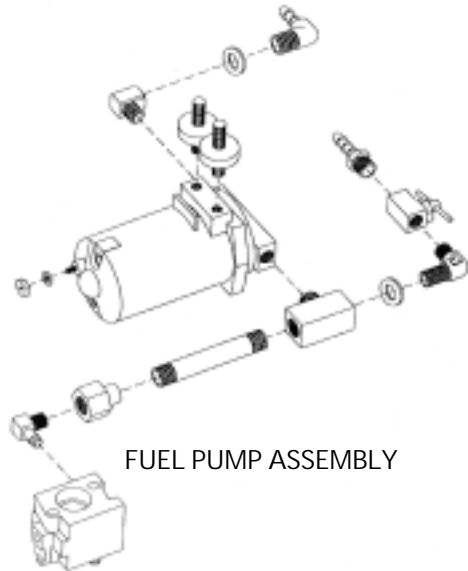
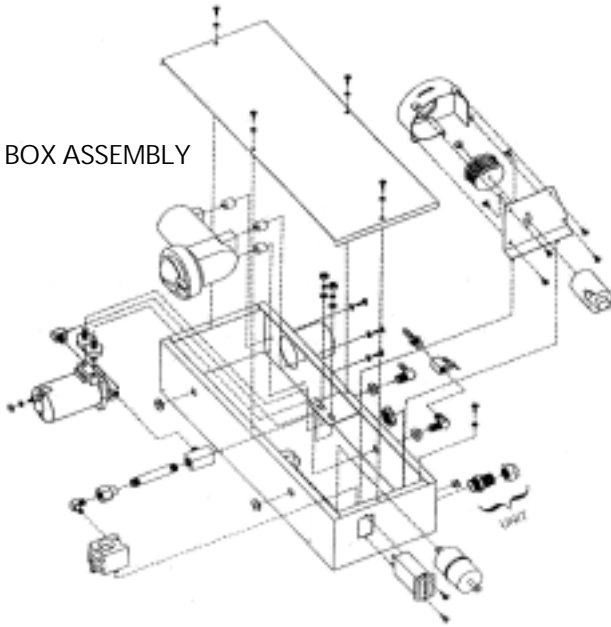

FUEL PUMP ASSEMBLY

# HURRICANE

